



Big Bore Brake Master Cylinder Fitting Tips.

IMPORTANT

ONLY USE NEW BRAKE FLUID

USE A PRESSURE BLEEDER TO BLEED THE BRAKES STARTING AT THE REAR CALIPERS 1ST

ADJUST THE BRAKE PEDAL PUSHROD SO THAT THERE IS 1MM GAP BETWEEN THE PUSHROD AND MASTER CYLINDER, SERVICE NOTE INFORMATION BELOW.

 **Lotus Service Notes** **Section JH**

15. Thinly coat the two reservoir spigots and sealing grommets with ATE Brake Cylinder Paste or ATE Brake Assembly Spray or similar, and insert the grommets into their locations in the master cylinder body. Fit the reservoir to the master cylinder with the two spigots fully inserted into their grommets. Ensure that the cap is positioned towards the rear with the clutch fluid take off on the left.
16. Lubricate the pushrod boot with rubber grease before fitting onto the end of the master cylinder, with its lip correctly located in the groove.
17. Fit the master cylinder assembly to the pedal box, inserting the brake pedal pushrod through the master cylinder boot to engage into the hollow of the rear piston. Retain with the two M8 bolts and tighten to ?? Nm (?? lbf.ft).
18. Check the pushrod length:
The pushrod length must be adjusted to apply a slight preload to the master cylinder with the pedal released. Too much preload will not allow the reservoir port to open. Too little preload will allow free play and a rattle from the pedal:
 - Remove the locking grub screw (3 mm key) in the end of the pedal trunnion, apply Permatbond A131 threadlock, and refit loosely;
 - Screw the pushrod into or out of the trunnion until the pedal just contacts the pedal box flange (upstop).
 - Apply ½ turn of preload to the pushrod, and tighten the trunnion lock screw to 5 Nm.

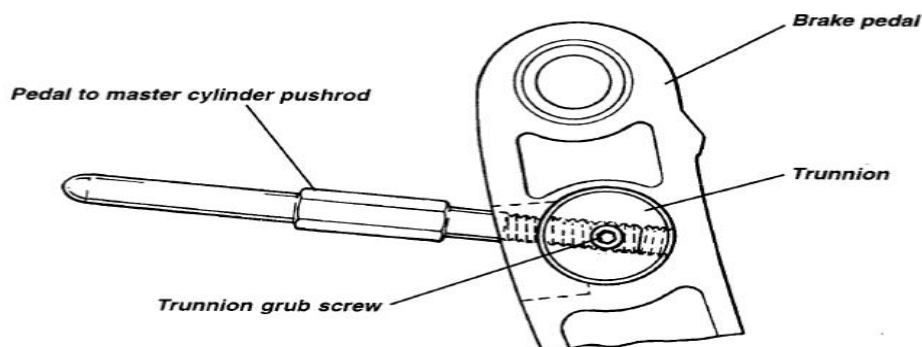

19. Check the stop light switch adjustment: With the pedal released, check that the switch plunger is depressed, with about 1 mm of the white plunger visible. If necessary, twist the switch body 90° counterclockwise to release from the quickthread, and reset its position to achieve specification.
20. Connect the brake pipes to the cylinder; rear circuit to the rear port, front circuits to the two front ports. Fit the clutch fluid supply hose to the reservoir spigot.
21. Fill the reservoir with DOT 4 non-mineral type brake fluid, and bleed the complete brake system of air using standard vacuum assisted, pressure assisted or manual techniques.